



# Tag Mount Installation Instructions for 2018 and Later Harley-Davidson® Softail® Breakout®

Technical Service Email: [support@cadencemotorsports.com](mailto:support@cadencemotorsports.com)  
Website: [www.cadencemotorsports.com](http://www.cadencemotorsports.com)

## GENERAL

### Kit Number

CMS-20231015-002

### Models

This product is only compatible with the 2018 and later Harley-Davidson® Softail® Breakout®.

### Installation Requirements

This product is designed to hold a standard North American motorcycle license plate and license plate frame with a combined weight not to exceed 2 (two) pounds. Do not attach anything other than a standard North American license plate and license plate frame to this mount.

Loctite 243 Medium Strength Thread locker and Sealant – Blue (HD Part number 99642-97) is required for proper installation of this product.

#### **⚠ WARNING**

**THIS PRODUCT IS DESIGNED TO BE INSTALLED AND USED ONLY ON MOTORCYCLES FITTED WITH AN OE SIZE REAR TIRE. INSTALLING THIS PRODUCT ON A MOTORCYCLE EQUIPPED WITH A LARGER REAR TIRE COULD RESULT IN DAMAGE TO THE MOTORCYCLE, DEATH OR SERIOUS INJURY TO THE RIDER, OR BOTH.**

#### **⚠ WARNING**

The rider's safety depends upon the correct installation of this product. Read and follow each step of these installation procedures. Use appropriate service manual procedures where available. If the procedure is not within your capabilities or you do not have the correct tools, have a qualified service technician or Harley-Davidson dealer perform the installation for you. Improper installation of this product could result in vehicle damage, death or serious injury, or both.

#### *NOTE*

*This instruction sheet references service manual and/or auxiliary Harley-Davidson product information that may be required to complete this installation. These are available from a Harley-Davidson dealer.*

#### **FEDERAL, STATE, AND LOCAL LAWS**

Check state and local laws regarding the use of this product and ensure that all laws are obeyed. Most states require tag illumination. Tag illumination and wiring may not be included. The tag mount has been designed to work with the OE reflector where required by law.

## PREPARATION

### Kit Contents

- 1 (one) tag mount
- 2 (two) Allen head bolts
- 2 (two) Nylock nuts
- 1 (one) 3" square foam pad
- 1 (one) alcohol wipe
- 1 (one) installation instructions
- 1 (one) Cadence Motorsports decal

## Tools Required

- T-47 Torx bit or 5/16" Allen wrench
- 7/23" Allen wrench
- 9/16" wrench
- Torque wrench

You may also need an assortment of wiring tools, voltmeter, soldering iron and solder, heat-shrink tubing and more based on your selected tag illumination choice.

## Wiring Plan

This product does not include any tag illumination wiring or detailed wiring instructions. Plan your tag illumination before you begin installation. Cadence Motorsports recommends the Cadence Motorsports curved illuminated tag frame (CMS-20230815-001).

#### *NOTE*

*You must de-pin and re-pin the brake light wiring and reroute the factory tag illumination light wiring to remove the factory tag mount. Seek assistance from a qualified wiring technician to ensure that your wiring is correctly connected and operating properly.*

#### **⚠ WARNING**

The OE routing for tag illumination wiring uses the external fender support rails. If you plan to route wiring through your OE rear fender, seek the assistance of a qualified service technician or Harley-Davidson dealer.

## INSTALLATION

#### **⚠ WARNING**

To prevent accidental vehicle start-up, which could cause death or serious injury, remove main fuse before proceeding. Refer to your service manual for the proper procedure for removing your main fuse.

#### **⚠ WARNING**

If motorcycle has been running, wait until engine and exhaust pipes have cooled before performing any installation steps to avoid injury. Secure the bike in a proper service stand.

#### *NOTE*

*If your motorcycle is equipped with the Harley-Davidson Holdfast Docking Kit, refer to the installation instructions for the Holdfast Docking Kit for proper installation and bolt torque procedures.*

1. Remove the seat and store it in a safe place away you're your work area.
2. If preset, remove the stick-on rear reflector mount (item #17 on FIG 1). It is stuck on with double-sided tape and can be removed with a light pressure. Use a hair dryer to soften the glue to aid in removal.
3. Take a photo of the brake and tag light connectors for use when you reconnect your lights after installing your tag mount. Disconnect the brake and tag light connectors.
4. Loosen, but do not remove, the six OE fender mount bolts from the fender rails (item #5 on FIG 1).

5. Remove the four OE fender rail bolts (item #1 on FIG 1) and carefully place the fender assembly upside down on a secure and padded work surface.

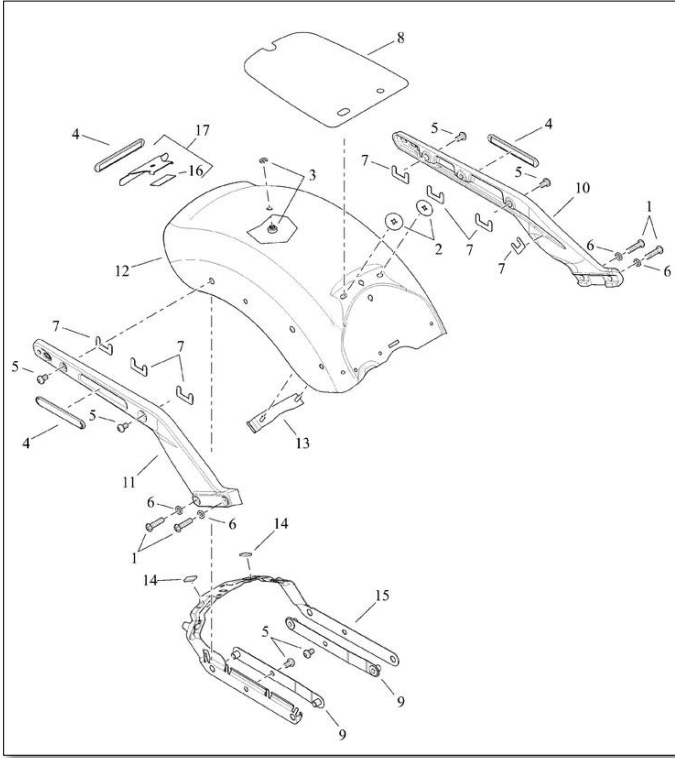

Fig 1

6. Remove the fender mount bolts (item #5 on FIG 1) that were loosened earlier from each side of the fender rails.

7. Remove the fender support bracket from the inside of the fender (item #15 on FIG 1).

8. The Breakout is delivered with either an OE side-mounted tag mount, or a large OE plastic fender mounted tag mount. If your Breakout has the plastic mount, remove it from the fender support bracket.

9. If your bike has the OE side mounted tag, remove the brake light mounting bolt from the end of the fender support. De-pin the brake and tag light wiring and remove the OE tag mount. You can reassemble the OE taillight using the stock OE short spacer or replace the OE spacer with a factory long spacer to match the right-side brake light spacer. (Harley-Davidson part #69438-06 chrome or Harley-Davidson Part #69933-08 black, not included). Reinstall the taillight using the OE taillight bolt and torque to Harley-Davidson specifications.

10. Using the supplied bolts and Nylock locking nuts, install your tag mount to the OE fender support bracket (FIG 2). Note that the nuts must face down for proper fender clearance.

11. Use the supplied alcohol wipe to clean and place the supplied self-adhesive rubber padding to the underside of the fender (Fig 3). This protects the underside of the fender from any contact with the mounting bolt heads due to fender manufacturing tolerance deviations.

12. Reinstall the support bracket to your fender and fender rails (item #15 on FIG 1).

13. Install your tag and/or tag frame. There may be additional steps depending on your choice of tag light. If you are installing a Cadence Motorsports lighted tag frame, refer to your Cadence Motorsports Lighted Tag Frame Installation Instructions to complete the tag light wiring now.

14. Apply LOCTITE 243 MEDIUM STRENGTH THREAD LOCKER AND SEALANT (BLUE) to the OE fender mounting bolts and tighten the bolts to the torque specifications recommended by Harley-Davidson (item #5 on FIG 1). Use caution not to pinch any wiring running through the fender support channels.



Fig 2

15. Apply LOCTITE 243 MEDIUM STRENGTH THREAD LOCKER AND SEALANT (BLUE) to the OE fender mounting rail bolts and re-install the rear fender assembly to the frame (item #1 on FIG 1). Tighten the frame rail bolts to the torque specifications recommended by Harley-Davidson.



Fig 3

16. Enjoy the new streamlined look of your motorcycle.

**NOTE**

*Avoid the use of pressure washers, harsh chemicals or abrasive cleaners as they may damage the finish of your tag mount.*